



water to water heat pump

Operational Manual

Please read the manual first before install machines.

Please maintain manual for easy reference.

➤ Summary

DF2SS-TS5 controller apply to water-cooled heat pump hot water heater, can control single or double compressors, the controller consists of outdoor main board and indoor control panel, and have fan coil linkage interface

➤ Main technical parameters

1、 Operating conditions

- Operating voltage: AC220V±10%
- Operating ambient temperature: -20~+55℃
- Storage temperature: -35~+85℃
- Moisture requirement: 0~95%RH

2、 Temperature control precision: 1℃

3、 Controller conform to

- GB4706. 1-1988 《Household and similar electric appliances safety Part I: General Requirements》
- GB4706. 32-1996 《Household and similar electric appliances safety, heat pump、 air-conditioners and dehumidifiers special requirements》
- GB18430. 1-2001 《Vapor compressor circulating cooling water(heat pump) units for industrial and commercial use and similar purposes in cold water (heat pump) units》
- GB18430. 2-2001 《Vapor compressor circulating cooling water(heat pump) units for industrial and commercial use and similar purposes in cold water (heat pump) units》
- AC noise interference conform to GB4343. 2-1999
- Printed circuit board conform to GB4588. 1 and GB4588. 2 regulate

➤ Controller functions

- 1、 Cooling running
- 2、 Heating running
- 3、 Show return water temperature of inner loop and preset temperature, with the inquiry functions
- 4、 Automatic memory of the parameters if power fails.
- 5、 The compressor runs balanced and start at different fixed time.
- 6、 Short phase protection and inverse phase sequence protection of three-phase supply.
- 7、 Perfect protection functions and displayed
- 8、 Have fan coil linkage interface
- 9、 Use Motorola high-performance chips, to have the best AC noise interference reduction.
- 10、 ON/OFF at definite time function
- 11、 Payment reminder function.

Note: in this document, “inside” mean is load side water loop., “outside” mean is heat source side water loop.

➤ Operation of control panel

Indoor control panel as follows :



1、 ON/OFF

- Press "ON/OFF" button, the machine powers on , the indicator lamp ON
- Press "ON/OFF" button again, the machine powers off, the indicator lamp OFF
- Both ON and OFF mode , data can be stored

2、 Mode change

- Press "mode" button, choose needed the mode, "cooling" or "heating" mode
- "cooling" mode shown snow symbol
- "heating" mode shown sun symbol

3、 Timing setting ON/OFF

(1) [b7] is 0 means combined defined time, (please read following section for setup):

- Under power on mode, set power off time..
- Under power off mode, power on time..
- Press "setting" for 3 seconds, "hour" time flash.
- Press "<+><->" , adjust definite "hour" time
- Press "<△>," minute" time flash.
- Press "<+><->" , adjust definite "minute" time
- Press "set" button , the definite time setting is finished .
- Press "ON/OFF, definite time is canceled.

(2) Set [b7] to 1 means set recurrent definite time

- Press "setting" for 3 seconds, "hour" time flash. begin to set definite time for power on.
- Press "<+><->" , adjust definite "hour" time , adjust definite "hour" time for power on
- Press "▽△," minute" time flash

- Press “<+><->” , adjust definite “minute” time for power on
- Press ”∇△”, ”hour” time flashes, the definite time setting for power on is finished ,enter the definite time setting for power off
- Press ”<+><->” , adjust the definite “hour” time for power off
- Press “∇△” , “minute” time flashes.
- Press ”<+><->” adjust the definite “minute” time for power off
- Press ”set “ the definite time setting for power off is finished.

(3) Clock setting

- Press”set “for 5 seconds, “hour” time flashes ,enter clock setting state .
- Press”<+><->” to adjust the “hour” clock.
- Press ”△”minute” time flashes .
- Press”<+><->” to adjust the “minute” clock.
- Press ”set “,clock setting is finished

4. Query

- Under recurrent definite time ([b7] is 1) ,press”check”button , will show real time.
- Press”check’ button,enter parameters inquiry state,press “∇△” can inquire about the parameters of d1 d2 d3 d4 d5 , press ”check”, then quit the query state.
- Press”∇△” ,to inquire about d1: inside loop outlet water temp,d2:inside loop return water temp. d3: ambient air temp, d4:outside loop outlet water temp. D5:outside loop return water temp.

5. Parameter setting

(1) Parameters setting for users(temperature setting)

- Press”set”button, enter temp setting for users, shows ”p1” and it’s parameter,then press”<+><->” to set the parameter of p1(temperature setting for cooling temperature) .
- Then press”∇△” , shows “p2” and it’s parameter,and then press”<+><->”, to set the parameter of p2(temperature setting for heating temperature) .
- press “set”button again,quit the parameter setting for users.

Temperature setting (table 1).

Parameter name	serial number	Factory-set	Maximum value	Minimum value
Set temperature under cooling mode	P1	12	30	[bb]
Set temperature under heating mode	P2	40	[bC]	25

(2) Parameter setting for administrator

- Press“set” button for 10 seconds,enter parameters setting for administrator(via password enter)
- Press”check”button,users can choose from [system functions setting menu], [protect temperature time menu] or [password menu]
- Press“∇△” can choose setting items in particular menu
- Press“<+><->” to adjust particular parameters.
- Press“set” button, to store data and quit setting..

Password entering : table2

Confirm the first two numbers of the password for repairer	S1	Xx
Confirm the middle two numbers of the password for repairer	S2	Xx
Confirm the last two numbers of the password for repairer	S3	Xx

After S3 , press”check”button,if the password accord with the repairer’ password, then enter table 3:

repairer's password modification, if accord with the factory's password, then enter factory's password modification, if not correct, then it shows [S1] again, need enter repairer's password modification again, if needn't modify password, press "check" button directly, then enter table4 menu.

Repairer's password modification, table 3

Modify the first two numbers of repairer's password	A1	Xx
Modify the middle two numbers of repairer's password	A2	Xx
Modify the last two numbers of repairer's password	A3	Xx
Reconfirm the first two numbers of the password	A4	Xx
Reconfirm the middle two numbers of the password	A5	Xx
Reconfirm the last two numbers of the password	A6	Xx

Repairer's default password: 555555, after finished setting, press "check" button, if the modified password accord with the reinput password, The password modification is successful, then enter next menu, otherwise, modification is invalid, [A1] shows again, need to re-input.

Factory password modification

Modify the first two numbers of factory password	A7	Xx
Modify the middle two number of factory password	A8	Xx
Modify the last two numbers of factory password	A9	Xx
Reconfirm the first two numbers of password	AA	Xx
Reconfirm the middle two numbers of password	Ab	Xx
Reconfirm the last two numbers of password	AC	Xx
Time of protection	Ad	00

Factory default password: 555555

- After finished setting, press "Set" button, if modified password accord with the reinput password, and press "check" button to confirm, then password modification is successful, then enters the next menu, otherwise, the modification is invalid, [A7] is shown again, need to set again.

System function setting, table 4

Parameter name	serial number	Factory-set	01	00
Operating mode	b1	1(0-1)	Heat pump mode	Single cooling mode
Compressor quantity	b2	02(01-02)		
Outside water pump working mode	b3	1(0-1)	Stop	non-stop
	b4	1(0-1)		
Choice of mode shift	b5	0(0-1)	Both under stand-by or running state can change operating mode	Under running state can't change operating mode
	b6			
Choice of combined /recurrent definite time setting	b7	0(0-1)	Recurrent definite time (circularly operate per 24-hour)	Combined definite time (just once effective within 24 hours)
Water flow protection when anti-freezing	b8	1 (0-1)	Protect	Not protect
Phase protection choice	b9	1(0-1)	Protect	Not protect
Compressor restart temperature difference	bA	02(02-08)		
The lower limit of cooling set	bB	10(2-20)		
The upper limit of heating set	bC	45(30-80)		
Water temperature compensation	bD	0(-10-+10)	Without compensation when Anti-freezing mode	
Times of protection	bE	3(1-7)		

Protection temperature time parameter, table 5

Parameter name	Unit number	Factory set	Maximum value	Minimum value
outside outlet water temperature too high protection when cooling	C1	55℃	80℃	30℃
inside outlet water temperature too low protection when cooling	C2	4℃	10℃	2℃
inside outlet water temperature too high protection when heating	C3	57℃	90℃	40℃
outside outlet water temperature too low protection when heating	C4	4℃	10℃	-10℃
Inside return water and outlet water temperature difference too large protection	C5	10℃	15℃	2℃
Outside return water and outlet water temperature difference too large protection	C6	10℃	15℃	2℃
Temperature at which electric heating enter anti-freezing	C7	5℃	8℃	-2℃
Temperature at which compressor enter anti-freezing	C8	3℃	8℃	-2℃
Protection of compressor start-up	C9	3 Minutes	15Minutes	3Minutes
Time of compressor running need to meet	CA	3 minutes	10 minutes	1 minute
Time of pressure checkout of shielding low pressure	Cb	3 minutes	60 minutes	0 minute
Duration of protection conditions	CC	3 minutes	10 Seconds	1second
Consistent checkout time of water flow switch	Cd	10 seconds	30seconds	1second
Interval of compressor start -up	CE	30 seconds	90seconds	10seconds

Outdoor main control board:

Definition of interface, table 6

Name	Number	Marker of interface	Functions	Explanation	Note
Analog input	1	A01	Inside outlet water temp	Temperature range : -30~80℃	L=2 meters
	2	A02	Inside return water temp	Temperature range: -30~80℃	L=5 meters
	3	A03	Outside environmental temp	Temperature range: -30~80℃	L=2 meters
	4	A11	Outside outlet water temp	Temperature range: -30~80℃	L=2 meters
	5	A21	Outside return water temp	Temperature range: : -30~80℃	L=2 meters
	6	A31			
Digital input	1	I01	linkage control	Dry contact input signal	Close normally
	2	I02	Inside water flow switch	Dry contact input signal	
	3	I03	Inside anti-frost switch	Dry contact input signal	
	4	I11	System 1 high pressure	Dry contact input signal	
	5	I12	System 1 low pressure	Dry contact input signal	
	6	I41	System 2 high pressure	Dry contact input signal	

	7	I42	System 2 low pressure	Dry contact input signal	
	8	I43	outside water flow switch	Dry contact input signal	
	9	I31	Outside anti-frost switch	Dry contact input signal	
Digital output	1	O01	Water pump	220VAC/20A	
	2	O02	Outside water pump	220VAC/7A	
	3	O11	Auxiliary electric heating	220VAC/5A	
	4	O21	2 # compressor	220VAC/5A	
	5	O22	1 # compressor	220VAC/5A	
	6	O31	4-way valve	220VAC/5A	
	7	O41	Warning output	220VAC/5A	

➤ Function description

1. Temperature Controlling Object

Temperature Controlling Object is inside return water temperature

2. Functions choice

Functions choice is according to table 3 setting item [b1], if [b1] parameter is "1", it is heat pump mode, if "0", it is single cooling mode.

3. Operating mode choice

Operating mode of system can be chosen as: cooling or heating. if [b1] is "0", it's single cooling mode, the running mode is fixed cooling. if [b5] is "1", then mode shift can be chosen under power ON/OFF state, otherwise, it just can be chosen under power OFF state.

4. Linkage function

When wiring controller is OFF state, linkage connect, power ON, linkage disconnect, power OFF

When wiring controller is ON state, Linkage connect, invalid, linkage disconnect, power off.

5. Outside water pump mode selection

When [b3] is "0", choose outside water pump non-stop mode.

When [b3] is "1", choose outside water pump stop mode, if need start compressor, outside water pump start 1 minutes in advance, and after outside water pump has started for 1 minute, compressor can be allowed start. And outside water pump should stop 1 minute later than compressor stop.

6. Selection of power ON/OFF at definite time functions.

By display panel, users can select following functions: power on at definite time, power off at definite time, combined definite time, recurrent definite time. Combined definite time is just effective once within 24 hours, recurrent definite time is effective all the time. Select combined definite time When [b7] is "0", select recurrent definite time when [b7] is "1".

7. Anti-freezing water flow protection selection

When [b8] parameter is "0", if water flow switch disconnect and not protect, continue anti-freezing under

system stand-by mode.

8. Phase protect function

If phase protection selection [b9] is “1”, system has lack of phase and wrong phase protect function, if “0”, no protect function.

9. [P1] the lower limit of cooling preset temperature should not be under the value of [bb]

10. [P2] the upper limit of heating preset temperature should not be higher than the value of [bC]

11. Water Temperature sensor compensation

In some special applications situation, if the sensor wire is too long or restricted by the installation location, should compensate and amend the sensor’s measuring temperature. This function can be achieved by adjusting the parameters of [bd], not compensate under anti-freezing mode.

12. Set protection times for the following systems: high and low pressure, inside and outside outlet water temperature, inside and outside inlet and outlet water temperature difference and so on., when system protect [bE] times within an hour, lockup this fault, otherwise can be reset.

13. Protection of outside outlet water temperature too high under cooling state.

Outside outlet water temperature higher than preset value of [C1] under cooling state, and last for 10 seconds, and the times of high temperature appears less than [bE] times / hour, compressor will be protected, the compressor will delay [C9] minutes to restart after outside outlet water temp reset; if high temperature appears more than [bE] times/hour, the controller will lockup this fault, the compressor will not restart whether outside outlet water temperature will reset or not.

14. Protection of anti-freezing under cooling state.

Inside outlet water temperature lower than the preset value of [C2] under cooling state, and last for 10 seconds, and the times of low temperature appears less than [bE] times/hour, compressor will protected, the compressor will delay [C9] minutes to restart after inside outlet water temp reset; if low temperature appears more than [bE] times/hour, the controller will lockup this fault, the compressor will not restart whether inside outlet water temperature will reset or not.

15. Protection of inside outlet water temperature too high under heating state.

Inside outlet water temperature higher than preset value of [C3] under heating state, and last for 10 seconds, and the times of high temperature appears less than [bE] times / hour, compressor will be protected, the compressor will delay [C9] minutes to restart after inside outlet water temp reset; if high temperature appears more than [bE] times/hour, the controller will lockup this fault, the compressor will not restart whether inside outlet water temperature will reset or not.

16. Protection of outside outlet water temperature too low under heating state.

Outside outlet water temperature lower than preset value of [C4] under heating state, and last for 10 seconds, and the times of low temperature appears less than [bE] times / hour, compressor will be protected, the compressor will delay [C9] minutes to restart after outside outlet water temp reset; if low temperature appears more than [bE] times/hour, the controller will lockup this fault, the compressor will not restart whether outside outlet water temperature reset or not.

17. Protection of temperature difference caused by water flow insufficient.

After the machine runs a period of time under cooling or heating state, if the temperature difference of outlet water temperature and return water temperature exceeds the preset value (inside [C5], outside [C6]), and lasts for 10 seconds, if the high temperature difference appears less than [bE] times / hour, the controller will carry out temperature difference protection caused by water flow insufficient, the compressor will delay [C9] minutes to restart after the temperature difference of outlet water temperature and return water temperature resets; if high temperature difference appears more than [bE] times/hour, the controller will lockup this fault, the compressor will not restart whether the temperature difference of outlet water temperature and return water temperature will reset or not.

18. Protection of anti-freezing in winter

In order to prevent indoor water freezing in the winter, the controller carries out protection of anti-frost in winter according to the parameters of [C7][C8]. Controller has two stage anti-freezing protection, at the first stage the cycle water pump starts up, auxiliary electric heating runs [C7], at second-stage protection, compressor starts up and heats the circulating water. [C8]

19. Protection of compressor running and delay to power off.

For the sake of protecting the compressor, the compressor can restart [C9] minutes later after the compressor stops.

When the compressor is running, except the air-condition shutdown or stop because of fault, it must over [CA] minutes, then it can stop.

20. Protection of high pressure of compressor

High-pressure switch disconnects for [CC] seconds, and this appears less than [bE] times / hour, the compressor will be protected, the compressor will restart [C9] minutes later after the high pressure resets, If high pressure appears more than [bE] times/hour, controller will lockup the fault, compressor will not restart whether the high pressure will reset or not.

21. Protection of low pressure of compressor

Low-pressure switch begins to detect after the compressor has started for [Cb] minutes, if the switch under disconnection state for [CC] seconds, and this appears less than [bE] times / hour, the compressor will be protected, the compressor will restart [C9] minutes later after the low pressure resets, If low pressure appears more than [bE] times/hour, controller will lockup the fault, compressor will not restart whether the low pressure will reset or not, must cut the electricity to reset.

22. Protection of water flow switch

After circulating water pump works for 30 seconds, the controller continuously detects the water flow switch under disconnection state for [Cd] seconds, then all of the load will be turned off to carry out the protection of water flow switch.

23. The function of loads' startup in sequence of time.

At central air conditioning system, there is a lot of powerful electrical equipment, such as compressor or auxiliary electric heater and so on, In order to avoid the startup and stop of these powerful equipment impacting on electricity grid, the controller controls their startup and stop according to the preset sequence of time.

24. Balance of compressor attrite running

In the process of running, compressors start up and stop circularly according to the sequence that which start up first then which stop first, to achieve all the compressors' working time are balance.

25. when cooling, inside anti-freezing switch disconnect, controller lockup the fault, and the compressor will not restart whether the inside anti-freezing protection reset or not. When heating, outside anti-freezing switch disconnect, controller lockup the fault, and compressor will not restart whether the outside anti-freezing protection reset or not.

➤ Control way

1、Cooling running

1. 1、Condition of compressor start up

- When $TI \geq [P1] + [bA]$, single compressor start up;
- When $TI \geq [P1] + [bA] + 2$, double compressors start up;

1. 2、Condition of compressor close,

- When $TI \leq [P1]$, close single compressor;
- When $TI \leq [P1] - 1$, close double compressor;

1. 3、Flowsheet of cooling running

Select cooling mode → machine start → water pump running → 4 way valve start → water flow switch detect → single compressor start up → double compressor start up

2、Heating running

2. 1、Condition of compressor start up:

- When $TI \leq [P2] - [bA]$, start single compressor;
- When $TI \leq [P2] - [bA] - 2^\circ\text{C}$, start double compressor;

2. 2、Condition of compressor close:

- When $TI \geq [P2]$, close single compressor
- When $TI \geq [P2] + 1$, close double compressor

2. 3、flowsheet heating running

Select heating mode → start machine → water pump running → four way valve running → water flow switch detect → auxiliary electric heating running → single compressor start up → double compressor start up

3、Electric heating operating

Only running under heating mode, if environment temperature lower than 12°C , working under following work mode:

$5^\circ\text{C} \leq TS-TI$, start auxiliary electric heating, $5^\circ\text{C} > TS-TI \geq 3^\circ\text{C}$, keep; $TS-TI < 3^\circ\text{C}$, close auxiliary electric heating

4、Automatic anti-freezing

In winter, machine stand-by, to protect the water pipes and pumps from frost crack, machine will enter anti-freezing state if it meet following condition.

- (1) Outside environment temperature lower than 10°C
- (2) Outlet water or return water temperature

- If outlet water or return water temperature \cong $[[C7]]$, start electric heater and water pump. When return water and outlet water temperature go up $2\text{ }^{\circ}\text{C}$, close the water pump and electric heater
- (3) When return water temperature or outlet water temperature \cong $[[C8]]$, start water pump, Automatically enter the heat pump running state until return water temperature $\cong 10\text{ }^{\circ}\text{C}$
Turn off all equipment, enter stand-by state.

➤ System failure protection and code

Controller automatically estimate all kinds of fault that appear under the system operating state, and according to the type of faults, to protects accordingly, and display the according code of the error. Error code show as

E1 : XX at the location of clock (88:88)

E 1 : XX
error error code

fault Table 7

The causation of fault	Fault code	Conditions of entering	Safeguard	The condition of restoration
Inside outlet water temperature sensor is damaged	E1:11	Sensor short circuit or open circuit	Machine stop	Repair or replace the sensor
Inside return water temperature sensor is damaged	E1:12	Sensor short circuit or open circuit	Machine stop	Repair or replace the sensor
Environment temperature sensor is damaged	E1:13	Sensor short circuit or open circuit	Machine stop	Repair or replace the sensor
Outside outlet water temperature sensor is damaged	E1:21	Sensor short circuit or open circuit	Machine stop	Repair or replace the sensor
Outside return water temperature sensor is damaged	E1:22	Sensor short circuit or open circuit	Machine stop	Repair or replace the sensor
Phase protection	E1:01	$[[b9]]$ is "1",lack of phase or reverse phase	Machine stop	Maintenance
Inside water flow switch disconnect	E1:02	Inside water flow switch Continuously disconnect for $[[Cd]]$ seconds,	Machine stop	Maintenance
Outside water flow switch disconnect	E1:03	Outside water flow switch Continuously disconnect for $[[Cd]]$ seconds,	Machine stop	Maintenance
Protection of inside anti-freezing switch for cooling	E1:04	Inside anti-freezing switch Continuously disconnect for $[[CC]]$ seconds,	Machine stop	Maintenance
Protection of outside anti-freezing switch for heating	E1:05	Outside anti-freezing switch Continuously disconnect for $[[CC]]$ seconds,	Machine stop	Maintenance
1# High pressure Fault	E1:31	1# High pressure switch disconnect	Stop 1#compressor	Maintenance
2# High pressure Fault	E1:32	2# High pressure switch disconnect	Stop 2#compressor	Maintenance
1# low pressure Fault	E1:41	1# Low pressure switch disconnect	stop 1#compressor	Maintenance
2# low pressure Fault	E1:42	2# Low pressure switch disconnect	Stop 2#compressor	Maintenance

Protection of outside outlet water temperature is too high when cooling	E1:51	Outside outlet water temperature is higher than the value of [C1] when cooling	Machine stop	Maintenance
Protection of inside outlet water temperature is too low when cooling	E1:52	Inside outlet water temperature is lower than the value of [C2] when cooling	Machine stop	Maintenance
Protection of inside outlet water temperature is too high when heating	E1:53	Inside outlet water temperature is higher than the value of [C3] when heating	Machine stop	Maintenance
Protection of outside outlet water temperature is too low when heating	E1:54	Outside outlet water temperature is lower than the value of [C4] when heating	Machine stop	Maintenance
Protection of temperature difference of inside outlet water and return water is too high	E1:55	The temperature difference of inside outlet water and return water higher than the value of [C5]	Machine stop	Maintenance
Protection of temperature difference of outside outlet water and return water is too high	E1:56	The temperature difference of outside outlet water and return water higher than the value of [C6]	Machine stop	Maintenance
Signal Error	E1:99	The main board can't deliver signals to the operate panel	Machine stop	Maintenance

Please replace the batteries regularly

➤ Wiring diagram of system

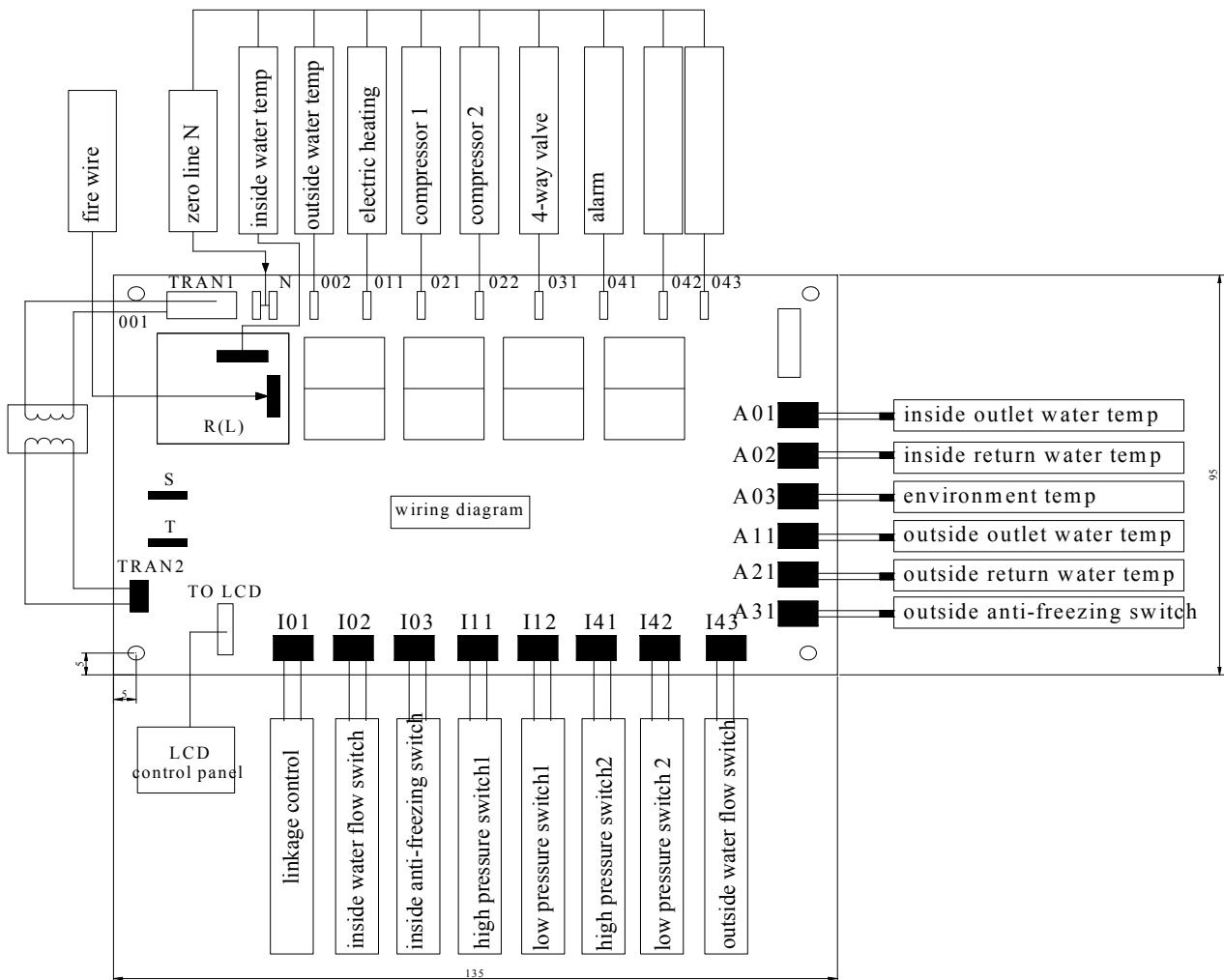

- Don't install the LCD control panels outdoor, please separate the strong electricity and weak electricity when wiring

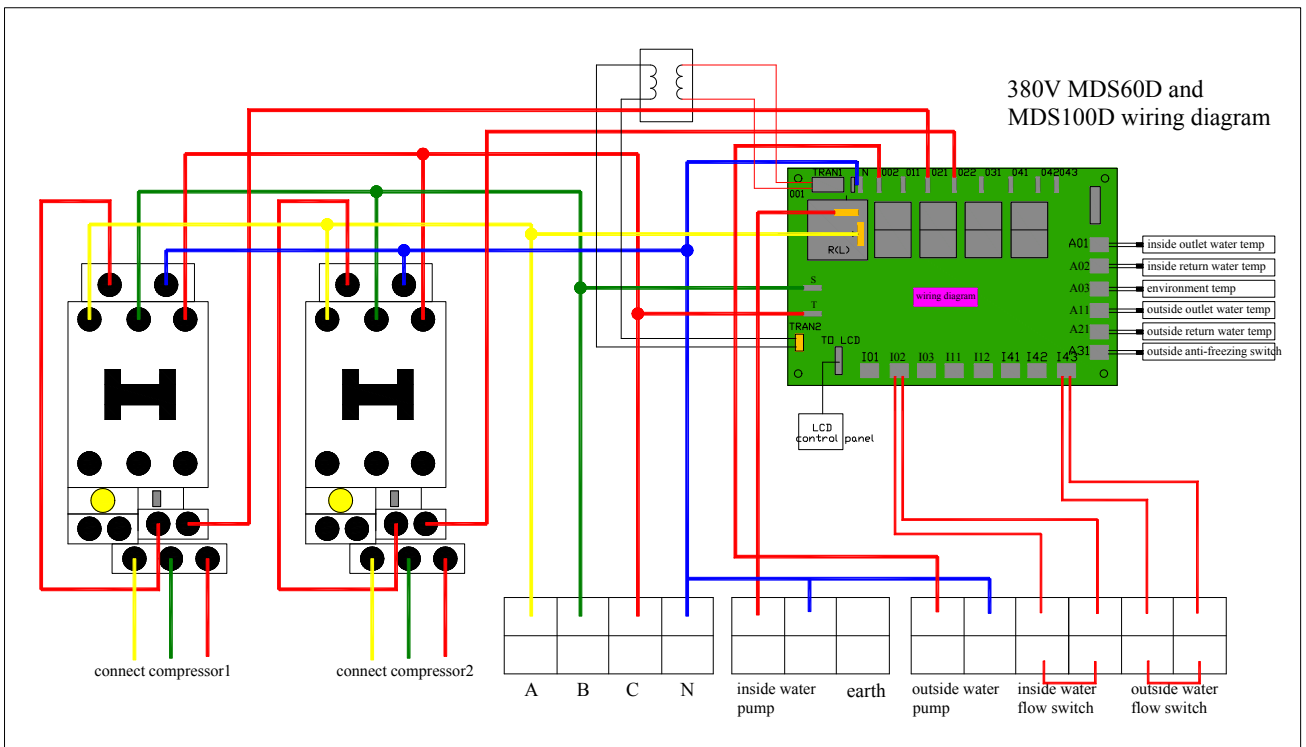
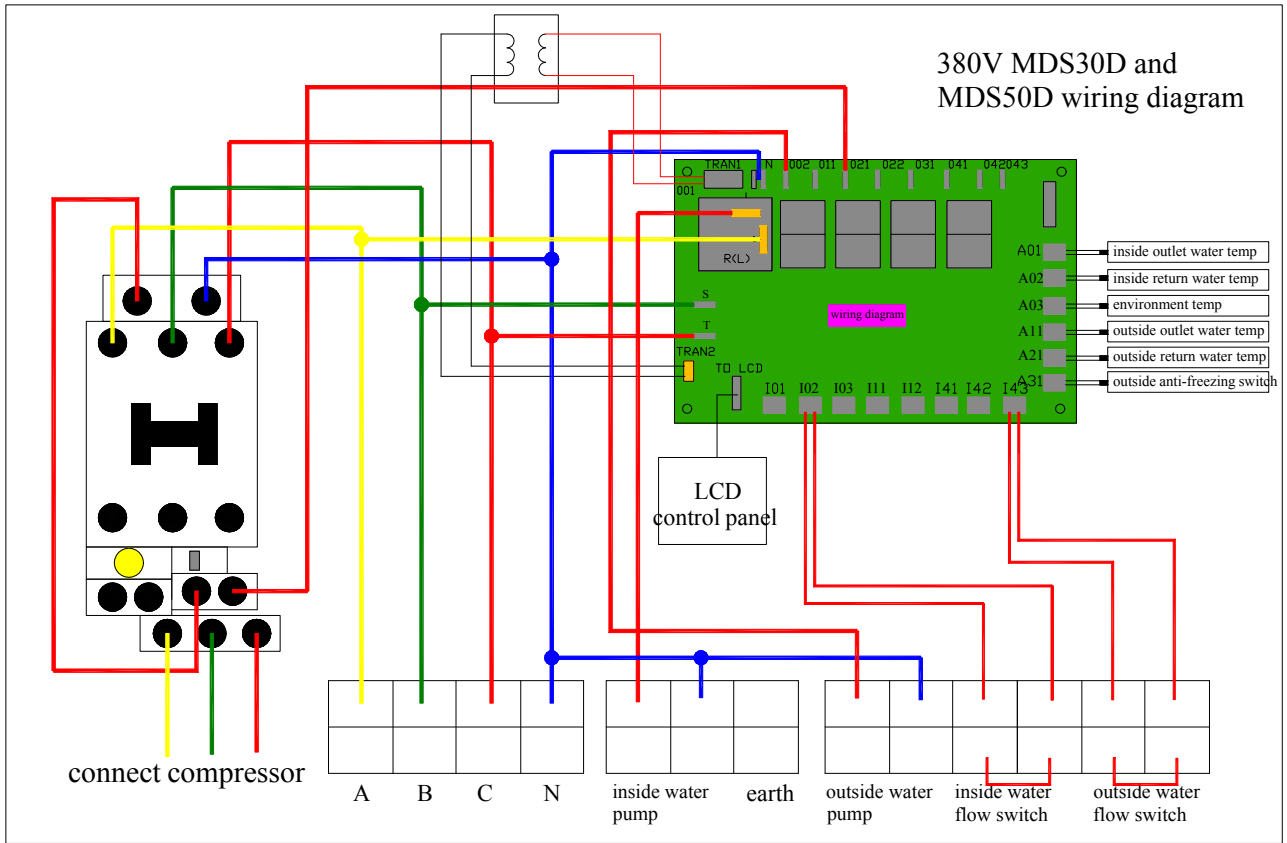

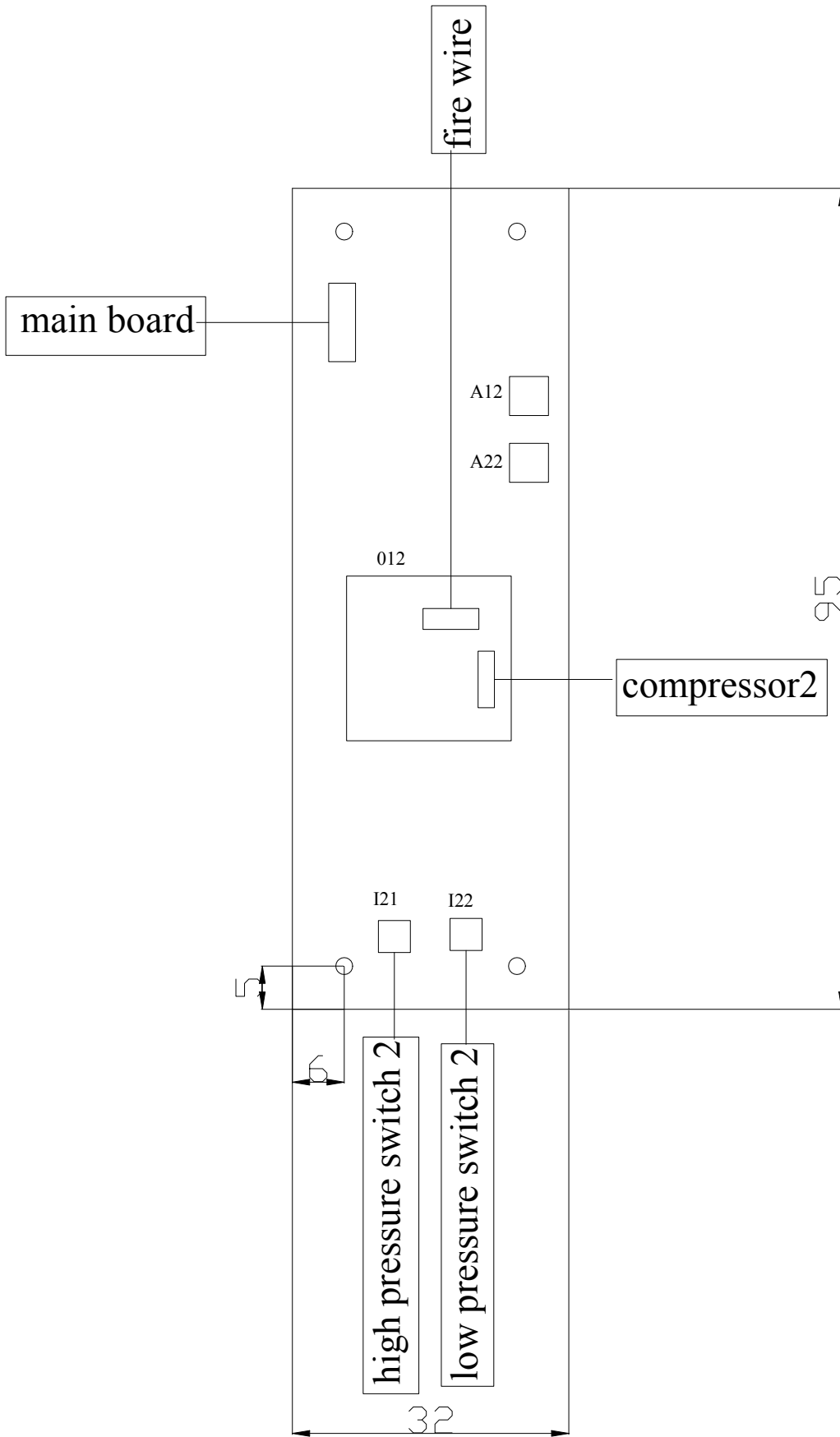

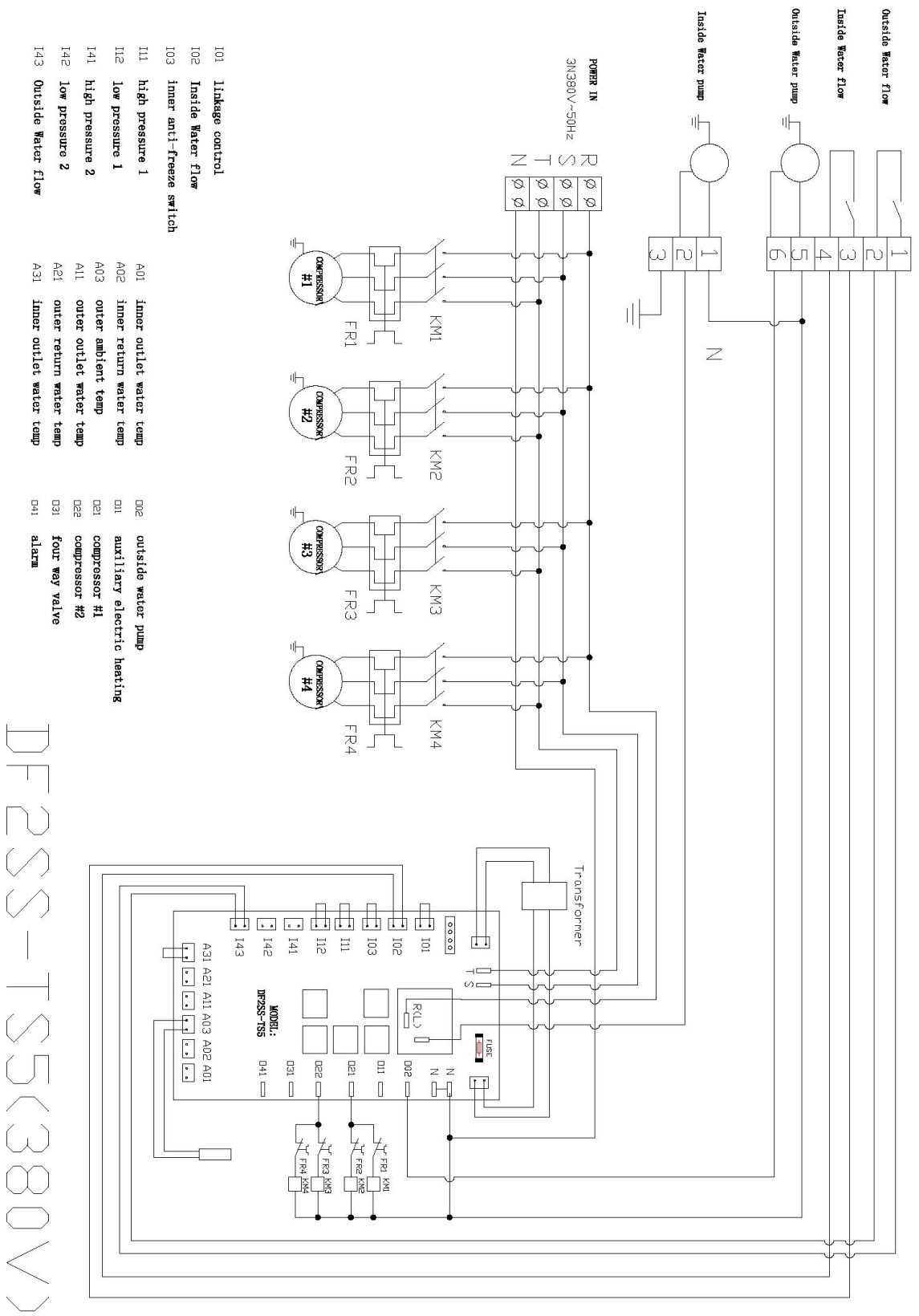

- 101 linkage control
- 102 Inside Water flow
- 103 inner anti-freeze switch
- 111 high pressure 1
- 112 low pressure 1
- 141 high pressure 2
- 142 low pressure 2
- 143 Outside Water flow

- A01 inner outlet water temp
- A02 inner return water temp
- A03 outer ambient temp
- A11 outer outlet water temp
- A21 outer return water temp
- A31 inner outlet water temp
- 002 outside water pump
- 001 auxiliary electric heating
- 021 compressor #1
- 022 compressor #2
- 031 four way valve
- 041 alarm

DF2SS-TSS(380V)

WARRANTY

Dear customers,

Thank you for using our products. We will supply you with complete after-services according to "SUN&DAY" and "New three guarantees of quality". Please read our instruction for more detail before using, so that you know how to install and use properly its excellent character of function. If you have any problems or suggestions, please contact the local agent or appointed Repair Company. They will give you good answer and better service.

The meanwhile, Please send the certification that you cut away from warranty card to our company after you install the heat pump in two weeks. We will record it validly, and then your heat pump will get repairs forever from the day when you brought it (Except the project machine which fix period is 1 year). During warranty period we can freely supply accessory. After that time you should pay for relevant material fee.

If there is problem, please write down the situation about problem & the No. of certification and inform our company, then we will send person to repair it. But the follow situations are beyond our free repair program.

1. The forces of nature caused the problem. A>Flood, earth quake, typhoon, snowstorm, and thunder and lightning. B>Please clean up the inside, water around condenser when not using it When temperature is below zero 5C degree and there is no electricity. Make sure it is not damaged by ice.
2. Incorrect action. For example: Didn't clean evaporator, lacking of water, not enough voltage and so on.
3. The problem caused by over use range. A>beyond the fixed temperature range, Using it when the voltage is too high or too low. B>the machine works continuously over 12 hours period leading to compressor damaged.
4. The problem caused by change circuit board or change accessory without permission
5. The problem caused by repairs, if done by someone not certified by our company.
6. The problem cause by incorrect installation. A> the mistake of mislead pipe B>the mistake of mislead cable. C>Modified products without permission.

We reserve the right of the problem of the final release

Repair record

Date	Reason	Repair company	Memory